



TRIVEX[®] System
Operation/Service Manual - English

TRIVEX[®] System

TABLE OF CONTENTS

PREFACE

This manual contains information you need to operate and maintain the LeMaitre Vascular TRIVEX® System. It is essential that you read and understand all the information in this manual before using or maintaining the system.

TABLE OF CONTENTS

Device Description	4	Service	14
Indications for Use	4	Returning the Control Unit	15
Contraindications	4	Troubleshooting	15
Warnings	4	Technical Specifications	16
Precautions	5	Ordering Information	17
System Components	6	Guidance and Manufacturer's Declaration –	
Resector Handpiece	6	Electromagnetic Emissions	17
Illuminator	6	Guidance and Manufacturer's Declaration	
Unpacking the Components	7	- Electromagnetic Immunity	17
Assembling the Control Unit to Cart	7	Guidance For Separation Distances	18
Assembling the Handle to Mast	7	Warranties	19
Control Unit Front Panel	7	Replacement Program	20
Console Controls and Functions	8	Repair Service Program	20
Power Switch	9	Symbol Legend	23
Fuse Panel	9		
Preoperative Setup	9	Figures	
Power Up	9	1. Component Identification	6
Tumescence Supply Setup	10	2. Assemble Control Unit To Cart	7
Resector Handpiece Saline Supply Setup	10	3. Control Unit Front Panel	7
Connecting the Resector Handpiece and Resector	10	4. Control Unit Display	8
Connecting the Illuminator	11	5. Control Unit Rear Panel	9
Operation	11	6. Tubing Connections	10
Resector Control	11	7. Fiber Optic Cable Inspection	11
Resector Handpiece Suction Control	12	8. Resector Handpiece Controls	11
Resector Handpiece Irrigation Control	12	9. Fully Opened Resector Handpiece Suction Lever	12
Resector Speed	12	10. Fully Closed Resector Handpiece Suction Lever	12
Cutting	12	11. Lamp	14
Window Lock	13		
Illuminator Irrigation	13		
Illuminator Control	13		
Cleaning And Sterilization	13		
Maintenance	14		
Electrical Interference	14		
Environmental Protection	14		
Preventative Maintenance	14		
Replacing The Lamp	15		
Fuses	15		

DEVICE DESCRIPTION

The TRIVEX System uses a metal halide arc lamp to provide intense, white light via the TRIVEX System Illuminator for transillumination. The illuminator connects with fiber optic cables to the TRIVEX System to provide transillumination during endoscopic resection of superficial varicosities of the lower extremities.

The TRIVEX System uses a pair of peristaltic pumps to provide irrigation and tumescence anesthesia for the Transilluminated Powered Phlebectomy procedure. The left hand pump is dedicated to providing the tumescence anesthesia via the TRIVEX System Illuminator. The right hand pump is dedicated to providing saline to the TRIVEX Resector Handpiece for resector tip irrigation.

INDICATIONS FOR USE

The TRIVEX System is indicated for use in ambulatory phlebectomy procedures for the resection and ablation of varicose veins.

CONTRAINDICATIONS

Use of the TRIVEX System is contraindicated in situations where ambulatory phlebectomy is contraindicated.

WARNINGS

Please read this manual before using the TRIVEX System. The brief operating instructions in this guide will make the system easier to use, while the recommended service and maintenance procedures will ensure optimal performance and reliable use. As with any surgical instrument, there are important health and safety considerations. These are listed below and reiterated within the text.

Prior to using the TRIVEX System, it is essential that all components of the system be inspected for damage that can negatively impact the equipment performance. The inspection should include all equipment to be used in surgery, including the illuminator, cables, and accessories.

When removing the TRIVEX System and accessories from the shipping container, inspect contents to ensure that all components from the "Unpacking the Components" section are available.

Contact your LeMaitre Vascular Representative if damage is noted.

- Before using the TRIVEX System for the first time, you should review all available product information. Surgeons should become familiar with this surgical technique and the TRIVEX System. You should be experienced in ambulatory phlebectomy surgery using powered instruments. Healthy tissue can be injured by improper use of the TRIVEX System resector. Use every available means to avoid such injury.
- TRIVEX Resector Kits are packaged as a set. They must be used as supplied. Do not interchange resector components.
- Illuminator inflow tube sets and resector kits are provided STERILE and are for single use only. Do not reuse. Do not resterilize. Prior to use, inspect the product package for signs of damage or tampering. Discard any opened and unused product. Do not use after the expiration date.
- Resterilization and/or re-use of the Illuminator Tube Sets or Resector Kits may cause mechanical damage to these products. This may result in injury to the patient or user.
- The TRIVEX System pumps should not be running while setting up the tubing. Injuries to the operator's hands can occur.
- Work exclusively with sterile substances, sterile fluids, and sterile accessories.
- This system is intended only for use with flexible fluid containers and fluid bags. Glass containers or bottles may break, and there is a risk of implosion.
- Use of bags or containers not approved for this system, or large and/or lopsided loads, may cause the device to tip over.
- If visualization is lost during any point in the procedure stop resetting immediately.
- Excessive pressure of the TRIVEX resector against the vessel or prolonged activation of the TRIVEX resector in a stationary position may result in perforation of the resector through the limb surface.
- Do not hold the light source shutter open without a fiber optic cable in place. Failure to observe this precaution may result in eye injury.
- During procedure, avoid prolonged contact of the Illuminator tip to patient tissue or flammable materials. The Illuminator tip may reach high temperatures due to high-intensity light transmission.
- DANGER: Risk of explosion if used in the presence of flammable anesthetics.
- When the light source is turned on, do not look directly at the metal halide arc lamp without protective goggles.
- To prevent electrical shock, do not remove the TRIVEX System console cover. There are no user-serviceable components inside. Dismantling the equipment will void the warranty. Refer servicing to LeMaitre Vascular.
- To prevent electrical shock, connect the power cord to a properly-wired grounding receptacle only.
- To prevent electrical shock, unplug the unit from the electrical outlet before attempting to replace the fuses.
- Use extreme caution: The high internal pressure of the lamp may cause an explosion, regardless of whether the lamp is cold or hot. Always wear protective clothing and a face mask when handling the lamp.
- Hazardous high voltage and energy are present at the output and in the internal circuitry of this unit.
- If this unit is configured as part of a system, the entire system should be tested for compliance with IEC 60601-1.
- If the leakage current of the configured system exceeds the limits of IEC 60601-1, install an appropriately rated UL 60601-1/IEC 60601-1 approved isolation transformer and retest the system.
- In some cases, high voltage may persist after the power has been removed. Only personnel qualified to service electronic equipment should operate or troubleshoot an "uncased" power supply.
- Dangerous voltages are present during leakage current testing. DO NOT TOUCH the TRIVEX System while power is applied.

- HIGH VOLTAGE (1500 VAC) is present during dielectric strength and Hi-Pot testing. Exercise extreme caution while operating the dielectric strength tester or the Hi-Pot tester to prevent personal injury from electrical shock or damage to the equipment. Ensure that only authorized personnel are in the test area during the tests.
- To avoid fire hazard, use only fuses of the correct type, voltage rating, and current rating.
- The use of accessory equipment not complying with the equivalent safety requirements of this equipment may lead to a reduced level of safety of the resulting system. Consideration relating to the choice shall include:
 - Use of the accessory in the patient vicinity.
 - Evidence that the safety certification of the accessory has been performed in accordance to the appropriate IEC 60601 Standard.

PRECAUTIONS

- U.S. Federal law restricts this device to sale by or on the order of a physician.
- Prior to use, examine the device(s) for possible damage to assure proper functioning. If damaged, do not use.
- Verify that the resector handpiece and its cable are sterile.
- Verify that the Illuminator, Light Guide and adaptors are sterile.
- Check to ensure that the resector(s) required for the procedure are available.
- Verify that the Preoperative Setup has been successfully completed.
- Only LeMaitre Vascular Disposable TRIVEX Resector Kits can be used with the TRIVEX System. Resectors used with the TRIVEX System are for single use only. Do not resterilize or lubricate the resectors. Dispose of the resectors after use.
- Use of reprocessed, single-use resectors may permanently damage, impede performance, or cause failure of your LeMaitre Vascular TRIVEX System. Use of such products may render any warranties null and void.
- Make sure the wheels on the TRIVEX System roller base are locked to prevent the system from rolling during setup and use.
- As in conventional ambulatory phlebectomy procedures, bruising, hematoma, and hemosiderin deposits have been observed in clinical studies utilizing the TRIVEX System.
- Disconnect power cord before cleaning the unit.
- Do not sterilize or immerse the TRIVEX System console in disinfectant.
- To prevent moisture from entering the handpiece cable during sterilization ensure that the protective cap is screwed on completely. Moisture can damage the cable or handpiece connectors.
- Do not allow the rotating portion of any resector to touch any metallic object such as the illuminator. Damage to both instruments is likely. Damage to the resector can range from a slight distortion or dulling of the resector edge to actual fracture of the tip in vivo. If such contact does occur, inspect the tip. If you find cracks, fractures or dulling, or if you have any other reason to suspect a resector is damaged, replace it immediately.
- Excessive leverage on the resector does not improve cutting performance and, in extreme cases, may result in wear and degradation of the inner assembly.
- Do not cool the resector handpiece by immersing it in cold water.
- Do not operate the resector in the open air for an extended period.
- Use only the TRIVEX Light Source Adaptor (REF 7210375) with this system. Use of any other light source port adaptor may cause reduced light emission from the fiber optic cable.
- The power switch must be turned off, and the power cord disconnected from the power source, before attempting to replace the lamp.
- Replace the lamp only with an appropriate LeMaitre Vascular lamp (REF 7210115) as specified for the TRIVEX System. Use of any other lamp will void the warranty.
- Lamp may be very hot. Use protective eyewear and gloves when handling lamp.
- Do not leave the operating light cord without an Illuminator attached on the patient or surrounding materials. The light cord tip may reach a high temperature due to the high intensity light.
- This unit complies with IEC 60601-1-2. However, the user must be aware that this does not necessarily ensure protection of the unit against interference from other devices.
- Do not operate at line voltage other than those stipulated on the back of the unit.
- Ensure that the available mains voltage matches the data listed on the label attached to the back of the control unit. Incorrect voltage can cause errors or malfunction, and may permanently harm the equipment.
- Handle the unit with care. If the unit is dropped or damaged in any way, it must be returned immediately for service.
- Electrical safety testing should be performed by a biomedical engineer or other qualified person.
- This equipment contains electronic printed circuit assemblies. At the end of the useful life of the equipment it should be disposed of in accordance with any applicable national or institutional related policy relating to obsolete electronic equipment.
- This equipment is designed and tested to minimize interference with other electrical equipment. However, if interference occurs with other equipment it may be corrected by one or more of the following measures:
 - Reorient or relocate this equipment, the other equipment, or both.
 - Increase the separation between the pieces of equipment.
 - Connect the pieces of equipment into different outlets or circuits.

- Consult a biomedical engineer.
- Equipment should be disposed of in accordance with local and/or federal codes and requirements

SYSTEM COMPONENTS

The TRIVEX System consists of a variety of components:

- The TRIVEX System control unit provides controls for the mode and speed of the TRIVEX Resector, for activation and flow of the tumescence and saline pumps, and for operation of the light source for the TRIVEX System Illuminator.
- The console includes a display for resector speed and LED indicators for pump flow rate.
- The four control buttons (tumescence pump, lamp, resector mode, and saline pump) have lighted indicators above and below each push button. These indicate the status of each component by illuminating steady green, flashing green, steady orange, or flashing orange.
- The front of the control unit has ports for connecting the illuminator, two footswitches, and resector handpiece.
- The TRIVEX System stand provides a mobile base for the TRIVEX System control unit and an irrigation mast for the saline and tumescence solution irrigation bags.
- The 50 watt metal halide arc lamp provides intense, white light via the TRIVEX System Illuminator.
- The TRIVEX Resector Handpiece drives the LeMaitre Vascular 4.5 mm TRIVEX Resector (REF 7209514) and 5.5 mm TRIVEX Resector (REF 7209515), and features push-button controls for resector operation.

RESECTOR HANDPIECE

The TRIVEX Resector Handpiece is a hand-held motor drive that is electrically connected to the control unit via a 10 foot (3 meter) cable. The resector handpiece drives the disposable resectors.

The resector handpiece and its cable are autoclavable (see "CLEANING AND STERILIZATION").

TRIVEX SYSTEM ILLUMINATOR

The TRIVEX System Illuminator (REF 7210351) and is used to instill tumescence solution and to transilluminate the targeted varicosities. Please see the TRIVEX System Illuminator Instructions for Use (R2596) for additional information.

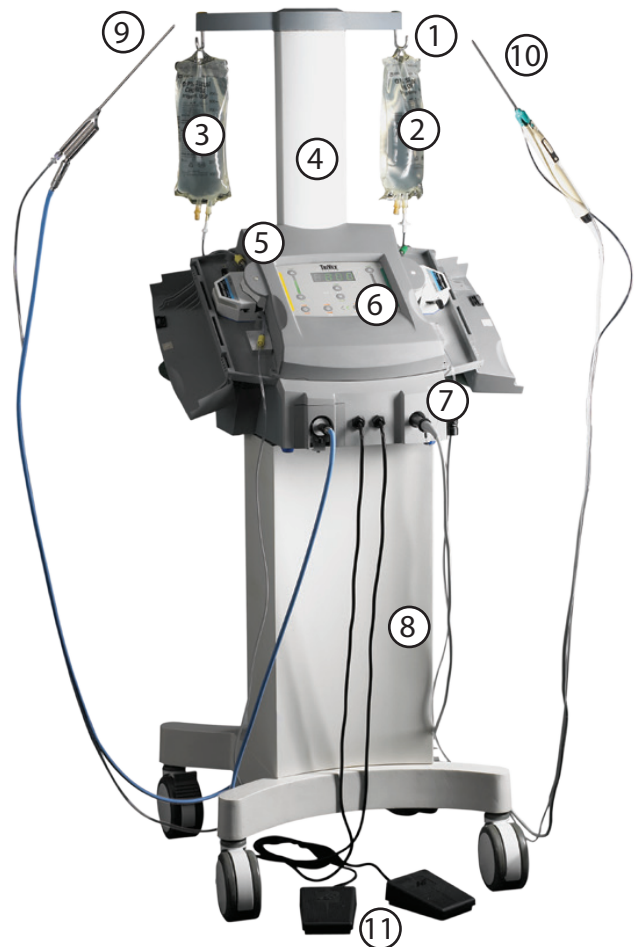

Figure 1: Component Identification

- | | |
|-------------------------------|------------------------------------|
| ① Fluid Bag Holder Hooks (x2) | ⑦ Connection Ports |
| ② Saline Solution Bag | ⑧ TRIVEX System Stand |
| ③ Tumescence Solution Bag | ⑨ TRIVEX System Illuminator |
| ④ Irrigation Mast | ⑩ TRIVEX System Resector Handpiece |
| ⑤ Control Unit | ⑪ Footswitch (x2) |
| ⑥ Control Unit Display | |

UNPACKING THE COMPONENTS

Carefully unpack and inspect all components shipped with your LeMaitre Vascular TRIVEX System. If any parts are missing or damaged, contact your LeMaitre Vascular representative. Save the carton and packing materials in the event a component must be returned for repair.

ASSEMBLE CONTROL UNIT TO STAND

1. Place the stand with roller base on a smooth level surface with the rear panel facing you.
2. Remove the 3/16" Allen wrench from the base of the irrigation mast. Using the Allen wrench, remove the four bolts securing the rear panel to the roller base.
3. Align the base of the control unit with the top of the roller base and lower the control unit straight down onto the roller base (figure 2).
4. For each of the four drawer latches located in the interior of the roller base: lift and engage the latch, then turn the latch key one half turn clockwise. Fold the latch key flat.
5. Replace the rear panel and reinsert the four bolts.

ASSEMBLE HANDLE TO MAST

6. Remove the four irrigation mast mounting bolts from the rear of the control unit.
7. Assemble the handle to the mast by: removing the two 1/4-20 x 5/8" socket head screws and washers from the handle using the 3/16" Allen wrench and then place the handle inside the box section of the mast weldment. Orient the handle so the threaded inserts align with the hole openings in the box section of the weldment. Secure the handle with the two, 1/4-20 x 5/8" socket head screws and washers.
8. Fit the irrigation mast with handle onto the rear of the control unit and secure it with the four irrigation mast mounting bolts.

CAUTION: Make sure the wheels on the TRIVEX System roller base are locked to prevent the system from rolling during setup and use.

TRIVEX SYSTEM CONTROL UNIT FRONT PANEL

CONTROL UNIT FRONT PANEL

1. Tumescence Pump Door – covers the tumescence pump hardware.
2. Saline Pump Door – covers the saline pump hardware.
3. TRIVEX System Display – contains the push buttons and displays for system operation.

FRONT PANEL CONNECTORS

There are four connectors on the front panel:

4. Fiber Optic Cable Connection Port – self-closing port designed to accept the TRIVEX Light Source Adaptor (REF 7210375).

CAUTION: Use of any other light source port adaptor may cause reduced light emission from the fiber optic cable or damage internal components, including the light source bulb.

5. Two Footswitch Tubing Connection Ports – accept tubing for the TRIVEX System footswitches.
6. Resector Handpiece Cable Connection Port (accepts the Resector Handpiece cable)

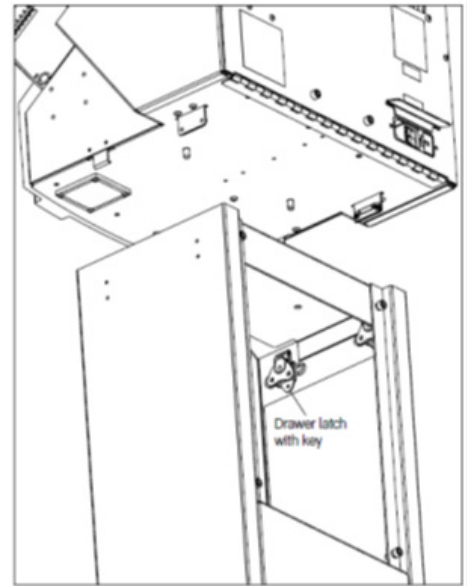

Figure 2: Assemble Control Unit to Stand

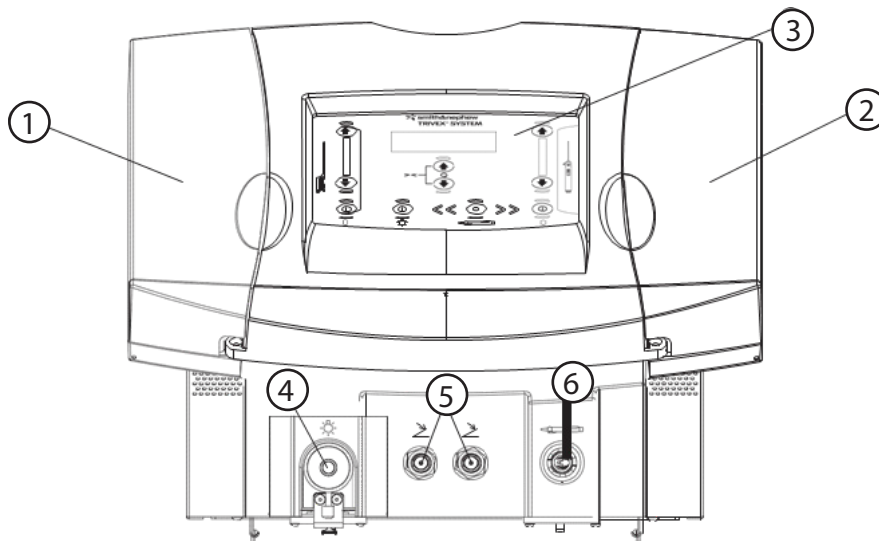

Figure 3: Control Unit Front Panel

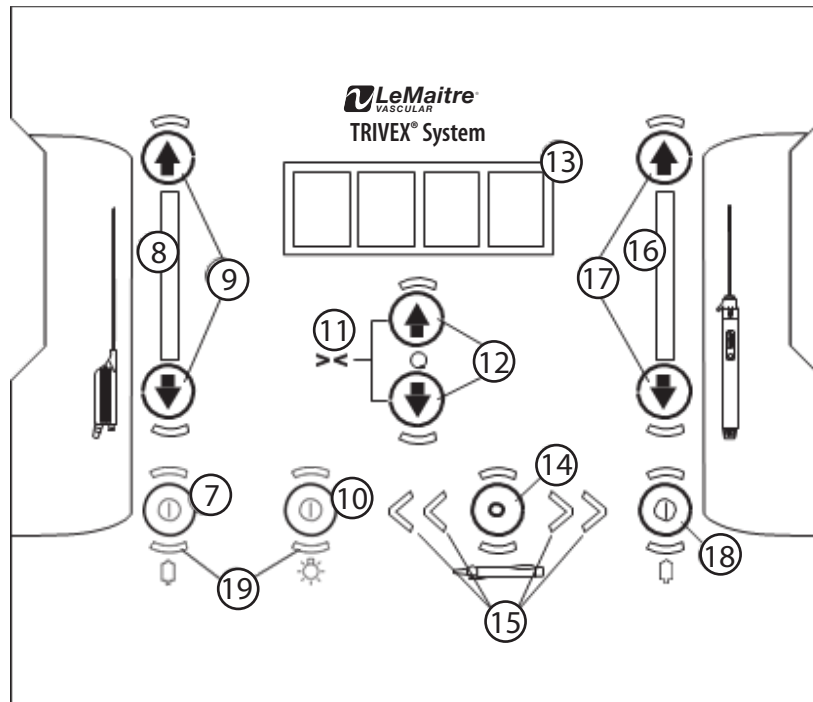

Figure 4: Control Unit Display

CONSOLE CONTROLS AND FUNCTIONS

7	Tumescence Pump ON/OFF Button	Turns the tumescence pump ON or OFF
8	Tumescence Pump Flow LED Indicators	Indicates the flow rate setting of the tumescence solution
9	Tumescence Pump Flow Increase / Decrease Buttons	Increase or decrease the flow rate of the tumescence pump. Each press of a button results in the flow rate increasing or decreasing by one level
10	Lamp ON / OFF Button	Turns the lamp ON or OFF
11	Window Lock Control	Holding down both Resector Speed Control increase/decrease buttons simultaneously engages the Window Lock function
12	Resector Speed Increase/ Decrease Buttons	Increase or decrease resector speed by 100 rpm with each button press
13	Resector Speed Display (rpm)	Displays the current speed of the resector incrementally in 100 rpm steps over a range of 100 rpm to 1500 rpm
14	Resector Mode Select Button	The Resector Mode button is used to change the resector direction between Oscillate, Forward, and Reverse
15	Resector Mode Indicators	When the resector is in Oscillate mode, a single arrow on each side of the Resector Mode Select button illuminates green (<>) When the resector is in Forward Mode, both right-side arrows illuminate green (>>) When the resector is in Reverse mode, both left-side arrows illuminate green (<<)
16	Saline Pump Flow LED Indicators	Indicates the flow rate setting of the Saline solution
17	Saline Pump Flow Increase / Decrease Buttons	Increase or decrease the flow rate of the Saline pump. Each press of a button results in the flow rate increasing or decreasing by one level
18	Saline Pump ON/OFF Button	Turns the Saline pump ON or OFF
19	Status Indicators	These indicators are located above and below the control buttons for the Tumescence Pump, Lamp, Resector Mode, and Saline Pump. They indicate the component's status by illuminating steady green, flashing green, steady orange, or flashing orange

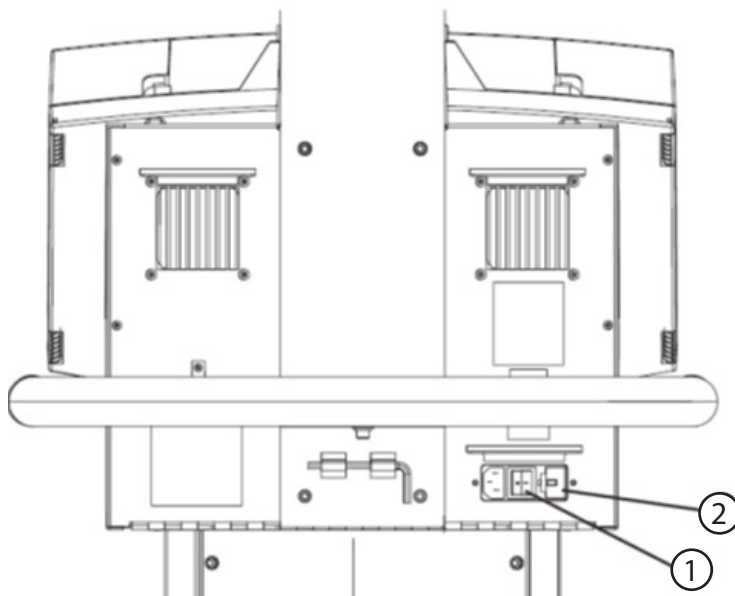

Figure 5: Control Unit Rear Panel

POWER SWITCH

The green rocker switch on the right side is the power ON/OFF switch for the entire system (1).

The switch is illuminated when the system is ON.

The three-prong electrical connector allows connection of the system to any 100 to 240 volt AC (50/60 Hz) source using the power cord supplied with the system. The system power supply automatically detects the local power standard and adapts the system to that standard.

FUSE PANEL

The control unit is protected by dual, 6.3 amp/250 volt time delay fuses mounted on the rear panel to the right of the green power switch (2).

NOTE: If system is turned off for any reason, wait at least 15 seconds before turning power back on.

PREOPERATIVE SETUP FOR USE IN A SURGICAL PROCEDURE

⚠ WARNING: Work exclusively with sterile substances, sterile fluids, and sterile accessories.

There are five main steps for preparing the TRIVEX System for use in a surgical procedure:

1. Power up - turn the TRIVEX System on and check for faults.
2. TRIVEX System Illuminator Tumescence supply setup - prepare the Tumescence solution and tubing.
3. Resector Handpiece saline supply setup - prepare the saline irrigation and tubing.
4. Resector Handpiece setup - connect the Resector Handpiece and verify operation.
5. Connect the TRIVEX System Illuminator and Tumescence Pump footswitches and verify operation.

POWER UP

CAUTION: Ensure that the available mains voltage matches the data listed on the label attached to the back of the control unit. Incorrect voltage can cause errors or malfunction, and may destroy the equipment.

WARNING: To prevent electrical shock, connect the power cord to a properly-wired grounding receptacle only.

1. Plug the unit power cord into the rear panel connector and a grounded AC power source. The control unit power supply automatically detects the local power standard and adapts the system to that standard.
2. Push the power switch on the rear panel to the ON (I) position.
3. The TRIVEX System will start up with these defaults:
 - Tumescence pump flow set to level four which corresponds to approximately 450 ml/min flow. Tumescence pump is OFF and Pump ON/OFF button is lit steady orange.
 - Saline pump flow is set to level one. Saline pump is OFF and pump ON/OFF button is lit steady orange.
 - Resector Mode is set to Oscillate (<>). The Resector Mode button will be lit steady orange if no Resector Handpiece is connected. The button will be lit steady green if a Resector Handpiece is connected.
 - Resector Speed is set to 500 rpm.
 - Lamp is OFF. Lamp ON/OFF button is lit steady orange.

NOTE: If the Resector Mode Select Button is flashing green or orange see "TROUBLESHOOTING".

NOTE: If the Lamp ON/OFF Button is flashing orange see "TROUBLESHOOTING".

TUMESCENCE SUPPLY SETUP

⚠ WARNINGS:

- This system is intended only for use with flexible fluid containers and fluid bags. Glass containers or bottles may break, and there is a risk of implosion.
 - Use of bags or containers not approved for this system, or large and/or lopsided loads, may cause the device to tip over.
1. Hang the tumescence solution bag from the left hand arm of the TRIVEX System irrigation mast.

NOTE: Fluid bags must only be hung on the bag holder hooks. Hang only one bag per hook. Maximum allowable volume is 3 liters.

2. Open the Tumescence Pump Door.
3. Move the Tumescence Pump Handle to the open position to allow loading of the tubing into the Tumescence Pump.
4. Insert the tumescence solution tubing into the Tumescence Pump, and snap the yellow tubing fittings into the corresponding yellow brackets. Ensure that the tubing rests securely in the tubing forks.

CAUTION: Use only the TRIVEX System Illuminator Inflow Tube Set (REF 7209513).

⚠ WARNINGS:

- The Tumescence Pump should not be running while setting up the tubing. Injuries to the operator's hands can occur.
 - Tube sets are provided STERILE and are for single use only. Do not reuse. Do not resterilize. Prior to use, inspect the product package for signs of damage or tampering. Discard any opened and unused product.
5. Close the Tumescence Pump using the Tumescence Pump Handle. Make sure the tubing forks do not pierce the tumescence solution tubing.
 6. Connect the tubing to the Tumescence solution bag.

NOTE: The Tumescence Solution tubing should only be connected to the TRIVEX System Illuminator.

7. Close the Tumescence Pump Door.

RESECTOR HANDPIECE SALINE SUPPLY SETUP

1. Hang the Saline solution bag from the right hand arm of the TRIVEX System irrigation mast.
2. Open the Saline Pump Door.
3. Move the Saline Pump Handle to the open position to allow loading of the tubing into the Saline Pump.
4. Insert the Saline solution tubing into the Saline Pump, and snap the green tubing fittings into the corresponding green brackets. Ensure that the tubing rests securely in the tubing forks.

CAUTION: Use only TRIVEX System Resector Kit tube sets (REF 7209514 or 7209515).

⚠ **WARNING:** The Saline pump should not be running while setting up the tubing. Injuries to the operator's hands can occur.

⚠ **WARNING:** Tube sets are provided STERILE and are for single use only. Do not reuse. Do not resterilize. Prior to use, inspect the product package for signs of damage or tampering. Discard any opened and unused product.

5. Close the Saline Pump using the Saline Pump Handle. Make sure the tubing forks do not pierce the saline solution tubing.
6. Connect the tubing to the Saline solution bag.

NOTE: The Saline Solution tubing should only be connected to the Resector Handpiece.

7. Close the Saline Pump Door.

CONNECTING THE RESECTOR HANDPIECE AND RESECTOR

CAUTION: Make sure the wheels on the TRIVEX System roller base are locked to prevent the system from rolling during setup and use.

1. Unscrew the protective cap from the connector end of the resector handpiece cable.
2. Connect the resector handpiece cable to the connection port on the front panel as follows: Orient the handpiece cable connector by aligning the white double arrows on the connector with the white dot on the connection port. The handpiece cable is fully engaged when the white arrows and the white dot are almost touching. Make certain the handpiece cable is fully inserted into the connection port.
3. Press and hold the Run button on the resector handpiece to confirm operation. The resector handpiece motor action can be observed by looking inside the distal end of the resector handpiece.
4. Remove the resector from the sterile package and insert the resector into the resector handpiece per the TRIVEX Resector Instructions for Use (R2590).
5. Press the Run button and observe the resector action to verify that it is properly installed.
6. Set the window lock position as described in the Operation section of this manual.

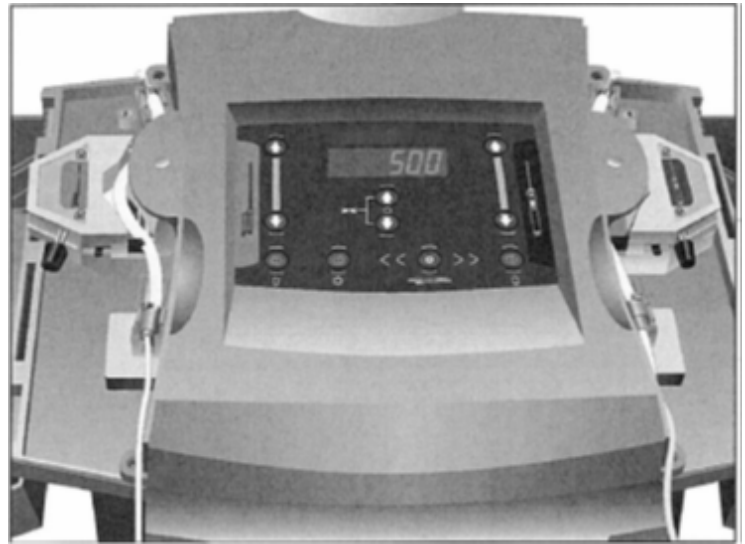

Figure 6: Tubing Connections

NOTE: The default directional mode setting for the resector handpiece is Oscillate.

7. Use the Resector Mode Select Button on the console to verify Forward and Reverse modes.

NOTE: If the Resector Mode Select Button is flashing green or orange, there is a problem with the resector handpiece. See the Troubleshooting section.

8. Connect the saline supply line from the Saline Pump to the inflow portal on the TRIVEX System resector.

9. Connect the suction by sliding the suction tubing onto the outflow portal on the proximal end of the resector handpiece.

NOTE: It is recommended that suction of -600 mm Hg be used for optimal resection performance.

CONNECTING THE ILLUMINATOR

! WARNING: Do not hold the shutter open without a fiber optic cable in place. Failure to observe this precaution may result in eye injury.

1. Check the fiber optic cable for damage. Cuts, abrasions, or tears in the silicone sheath covering the fiber optic cable will reduce overall light transmission.
2. While aiming one end of the cable toward a bright light, inspect the other end for damaged fibers, e.g., black dots or dark areas (Figure 7). Excessive numbers of broken fibers in the cable will result in reduced light transmission.
3. Connect the TRIVEX System Illuminator to the instrument end of the fiber optic cable using the ACMI® instrument end adaptor (REF 2141) included with the TRIVEX System.
4. Attach the TRIVEX Light Source adaptor (REF 7210375) to the system end of the fiber optic cable. Press the shutter button and insert the light source end of the fiber optic cable into the light source port. To remove the cable, press the shutter button and then withdraw the cable.

CAUTION: Use only the TRIVEX Light Source adaptor (REF 7210375) with this system. Use of any other light source port adaptor may cause reduced light emission from the fiber optic cable and may cause damage to the system light bulb.

5. Connect the Tumescence inflow tubing to the Illuminator.

6. Connect the Tumescence Pump Footswitches to the Footswitch connectors.

NOTE: The TRIVEX System starts up with the Tumescence pump OFF. The Tumescence Pump must be turned on using the Tumescence Pump ON/OFF button before the footswitches will work.

! WARNING: Possible explosion hazard if used in the presence of flammable anesthetics.

OPERATION

CAUTIONS

- Before using the TRIVEX System for the first time, you should review all available product information.
- Verify that the resector handpiece and its cable are sterile.
- Verify that the illuminator and the light guide cable are sterile.
- Check to ensure that the resector(s) required for the procedure are available.
- Verify that the Preoperative Setup has been successfully completed.
- Only LeMaitre Vascular Disposable TRIVEX Resector Kits can be used with the TRIVEX System Control Unit. The resectors are intended for single use only. Do not resterilize. Do not lubricate resectors. Discard the devices after use.
- Make sure the wheels on the TRIVEX System roller base are locked to prevent the system from rolling during setup and use.

RESECTOR CONTROL

There are two button controls on the Resector Handpiece (Figure 8). Press and hold the Run button to start the resector. The resector will run in the selected mode (Forward, Reverse, or Oscillate) until the button is released.

On startup, the TRIVEX System will default to Oscillate mode. The Resector Mode Select button indicator will glow green when a resector handpiece is connected.

For problem conditions with the Resector Handpiece the TRIVEX System will light the indicator bracketing the Resector Mode Select button. There are three possible indicators: a flashing orange light indicates a stalled motor or high current condition; a steady orange light indicates the TRIVEX System cannot detect a Handpiece; and a flashing green light indicates a problem with the Handpiece itself. (See "TROUBLESHOOTING" for additional information.)

The Window Lock function determines the stop position of the inner resector relative to the

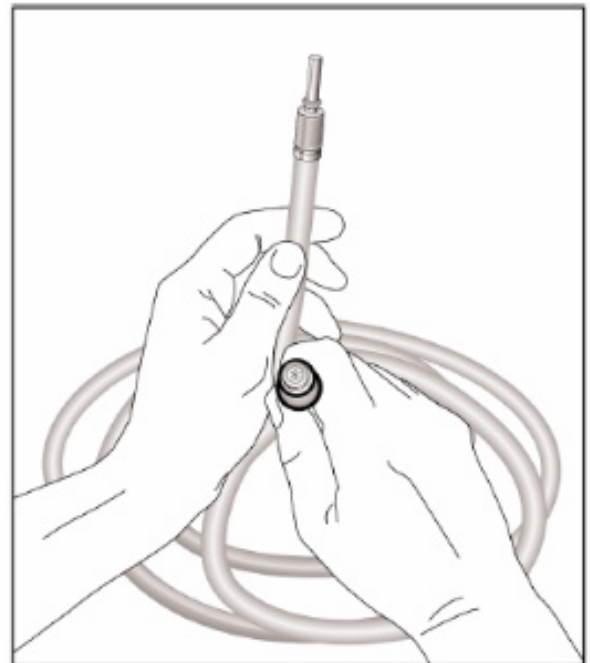

Figure 7: Fiber Optic Cable Inspection

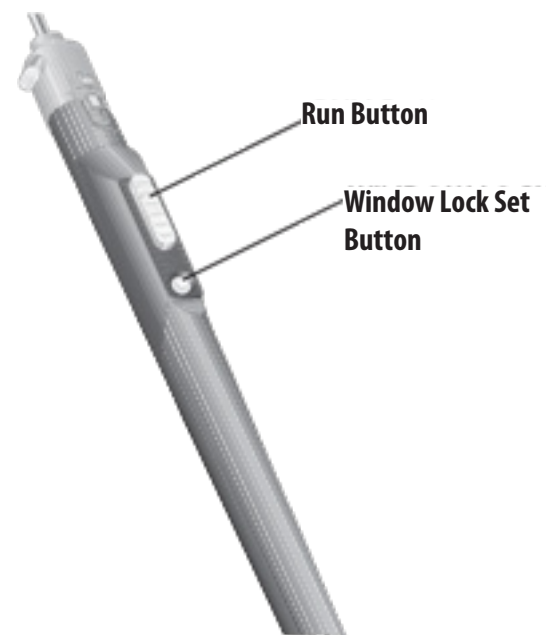

Figure 8: Resector Handpiece Controls

opening in the outer resector. Press and hold the Window Lock Set button to set the Window Lock. The Window Lock will rotate while the button is pressed. Release the button when the Window Lock has reached the desired position.

NOTE: The Resector Window Lock can also be set from the TRIVEX System control console unit console by pressing and holding the Resector Speed Increase and Decrease buttons simultaneously.

RESECTOR HANDPIECE SUCTION CONTROL

The TRIVEX System uses standard hospital suction. For optimal resection a suction pressure of -600 mm Hg is recommended. Suction is connected to a portal on the proximal end of the resector handpiece and removes fluid and debris drawn through the resector window. In addition to removing fluids, the suction fluid cools and lubricates the motor drive.

A lever on the proximal end of the resector handpiece provides suction flow control. The lever can be adjusted from fully opened to fully closed to provide immediate manual control of the suction rate.

1. When lever is aligned with arrow indicator (figure 9), the suction flow rate is maximized.
2. When the lever is perpendicular to the arrow indicator (figure 10), the suction flow rate is shut off.



Figure 9: Fully Opened Resector Handpiece Suction Lever



Figure 10: Fully Closed Resector Handpiece Suction Lever

RESECTOR HANDPIECE IRRIGATION CONTROL

Turn the Saline Pump on using the Saline Pump ON/OFF Button. The TRIVEX System defaults to a Saline Pump Flow setting level of one on startup. This is approximately 50 ml/min. The Saline Pump will only run while the Resector Handpiece Run button is held down.

The Saline Pump Flow can be increased or decreased by pressing the Flow Increase or Flow Decrease buttons located above and below the Saline Pump Flow Display. The Saline Pump has five Flow settings. The approximate flow rates for the pump fall between 50 ml per minute and 175 ml per minute.

NOTE: The Saline Pump ON/OFF Button glows orange when the pump is off and glows green when the pump is on.

NOTE: While operating the Resector Handpiece be sure that the saline pump is turned ON.

RESECTOR SPEED

The resector speed display indicates the current speed of the resector in rpm. When the TRIVEX System is turned on, the system is set to a default resector speed of 500 rpm. Use the increase and decrease push-buttons below the console display to set the actual speed of the resector. Pressing the increase and decrease buttons simultaneously will enable the Window Lock function.

Each press of a button will increase or decrease the speed of the resector by 100 rpm. The Resector speed can be set to any 100 rpm increment between 100 rpm and 1500 rpm.

The Forward (>>) and Reverse (<<) arrows that bracket the Resector Mode Select button indicate the resector direction.

CAUTION: Do not allow the rotating portion of the resector to touch any metallic object such as the illuminator. Damage to both instruments is likely. Damage to the resector can range from a slight distortion or dulling of the resector edge to actual fracture of the tip in vivo. If such contact does occur, inspect the tip. If you find cracks, fractures or dulling, or if you have any other reason to suspect a resector is damaged, replace it immediately.

CAUTION: Excessive leverage on the resector does not improve cutting performance and, in extreme cases, may result in wear and degradation of the inner assembly.

CUTTING

Cutting takes place when the resector edge of the inner tube rotates across the resector's outer window. The resector action alternately opens and closes the window to modulate the suction flow.

WINDOW LOCK

With the Window Lock feature, the resector handpiece can be set to stop the resector in a specific position. The window can be fully opened or closed, or somewhere in between, depending on the technique requirement. Pressing the Window Lock button on the resector handpiece, or pressing the increase and decrease buttons on the console simultaneously will engage the Window Lock function.

CAUTION: Do not operate the resector in the open air for an extended period, as the lack of irrigation may cause the resector to overheat and seize.

TRIVEX SYSTEM ILLUMINATOR IRRIGATION

Turn the Tumescence Pump on using the Tumescence Pump ON/OFF Button. The TRIVEX System defaults to a Tumescence Pump Flow setting level of four on startup approximately 450 ml/min.

The Tumescence Pump Flow can be increased or decreased by pressing the Flow Increase or Flow Decrease buttons located above and below the Tumescence Pump Flow Display. The Tumescence Pump has five Flow settings. The approximate flow rates for the pump fall between 300 ml per minute and 500 ml per minute.

NOTE: The Tumescence Pump ON/OFF Button glows orange when the pump is off and glows green when the pump is on.

Press and hold either footswitch to start the Tumescence Pump. Release the footswitch to stop the pump.

NOTE: The TRIVEX System starts up with the Tumescence pump OFF. The Tumescence Pump must be started using the Tumescence Pump ON/OFF button before the footswitches will work.

TRIVEX SYSTEM ILLUMINATOR CONTROL

Turn the illuminator lamp on using the Lamp ON/OFF Button. When the TRIVEX System lamp is first turned on the button will flash green for 10 seconds while the system does a lamp check.

When the lamp is off the Button glows orange. Each time the lamp is turned off, it will enter a 30-second cool-down cycle. This 30-second cycle is in addition to the 10-second lamp check cycle. As a result, the lamp button can flash green for up to 40 seconds before switching to a steady green glow.

In the event that the lamp does not light after the self-check cycles, the lamp button will flash orange.

CLEANING AND STERILIZATION

RESECTOR HANDPIECE

Follow these steps after each procedure to sterilize the resector handpiece:

1. Dispose of the resector and tube set used during the procedure following standard protocols for disposal of biohazardous waste.

CAUTION: Resectors and tube sets used with the TRIVEX System are for single use only. Do not resterilize. Discard after use.

2. Disconnect the resector handpiece cable from the front panel. Do not disconnect the cable from the handpiece. Screw the protective cap on to the connector end of the cable.

CAUTION: To prevent moisture from entering the handpiece cable during sterilization ensures that the protective cap is screwed on completely. Moisture can damage the cable or handpiece connectors.

3. Set the suction lever to fully open by aligning the lever with the double arrows.

NOTE: Use care not to lose the suction control lever O-ring if the suction control lever is removed.

4. Clean the unit thoroughly with soapy water. The unit may be immersed.
5. Clean the drain tube with a brush. Rinse the unit thoroughly with water. Do not use saline or solvents such as alcohol or acetone.
6. Sterilize the handpiece using one of the following methods:
 - Steam, pre-vacuum, wrapped at 270° F to 275° F (132° C to 135° C) for four minutes.
 - Steam, gravity method, wrapped at 270° F to 275° F (132° C to 135° C) for ten minutes.

CAUTION: Do not cool the resector handpiece by immersing it in cold water.

TRIVEX SYSTEM CONTROL UNIT AND FOOTSWITCHES

The TRIVEX System control unit operates outside of the sterile field and does not require sterilization. Sterilization and/or disinfection procedures will damage the product and void the warranty. Follow these steps after each procedure to clean the control unit:

1. Disconnect the TRIVEX System from the electrical source.
2. Wipe the console with a clean damp cloth and mild germicide or isopropyl alcohol.

CAUTION: Do not sterilize or immerse the TRIVEX System console in disinfectant.

Wipe the footswitches and footswitch cables with a clean damp cloth. The footswitches (REF 7209791) are watertight per IPX8.

FIBER OPTIC CABLE

See the Fiber Optic Cable Instructions for Use (R2603) for proper cleaning and sterilization procedures.

TRIVEX SYSTEM ILLUMINATOR

See the TRIVEX System Illuminator Instructions for Use (R2596) for proper cleaning and sterilization procedures.

MAINTENANCE

ELECTRICAL INTERFERENCE

CAUTION: This equipment is designed and tested to minimize interference with other electrical equipment. However, if interference occurs with other equipment it may be corrected by one or more of the following measures:

- Reorient or relocate this equipment, the other equipment, or both.
- Increase the separation between the pieces of equipment.
- Connect the pieces of equipment into different outlets or circuits.
- Consult a biomedical engineer.

ENVIRONMENTAL PROTECTION

CAUTION: This equipment contains electronic printed circuit assemblies. At the end of the useful life of the equipment it should be disposed of in accordance with any applicable national or institutional related policy relating to obsolete electronic equipment.

PREVENTATIVE MAINTENANCE

Recommended Electrical Safety Checks

Three safety tests are conducted on each unit during factory acceptance testing:

- Dielectric Strength Test
- Ground Continuity Test
- Leakage Current Test

LeMaitre Vascular recommends that these tests be performed regularly to assure continued compliance with applicable safety requirements. These tests should be conducted in accordance with specifications IEC 60601-1.

CAUTION: Electrical safety testing should be performed by a biomedical engineer or other qualified person.

WARNING: HIGH VOLTAGE is present during electrical safety testing. Exercise extreme caution to prevent personal injury from electrical shock, or damage to the equipment. Ensure that only authorized personnel are in the test area during the tests.

Recommended Periodic Cleaning

LeMaitre Vascular recommends periodic cleaning of the fan screens on the rear panel of the TRIVEX System control unit. Use a soft brush to loosen and remove any dirt that may have collected on the fan screens.

CAUTION: Excessive dirt buildup may reduce air flow from the fans and cause overheating.

SERVICE

Appropriate servicing of the TRIVEX System involves field replacement of fuses, the lamp damaged or worn handpiece cable, fiber optic cable, or damaged or worn power cord. All other repairs should be performed by LeMaitre Vascular.

See "ORDERING INFORMATION" for a list of replacement parts.

SERVICE PHILOSOPHY

There are no user serviceable components inside the TRIVEX System Control Unit. Repairs and adjustments are to be performed only by LeMaitre Vascular service centers.

If service becomes necessary, contact LeMaitre Vascular Customer Service prior to returning the device to request a Return Goods Authorization (RGA) number. Items to be serviced should be carefully repackaged and returned LeMaitre Vascular. Daily rentals are available as needed. A replacement program is available, contact your LeMaitre Vascular representative for details.

NOTE: Product returned that is found to have been serviced by an unauthorized third party repair facility and/or sterilized with a sterilization method other than one approved by LeMaitre Vascular will incur additional costs, regardless of warranty status.

It is not necessary to include accessory items (i.e., power cords, etc.) when returning a device for service.

REPLACING THE LAMP

1. Pull knob on Lamp assembly drawer down and pull drawer out.
2. Disconnect Lamp
3. Using provided screwdriver, remove circuit boards (as necessary) and unlatch lamp.
4. Replace Lamp
5. Latch brackets, connect lamp, and reinstall circuit boards (as necessary)

CAUTION: Replace the lamp only with an appropriate LeMaitre Vascular Replacement Lamp (REF 7210115) as specified for the TRIVEX System. Use of any other lamp will void the warranty.

CAUTION: Lamp may be very hot. Use protective eyewear/gloves when handling the lamp.

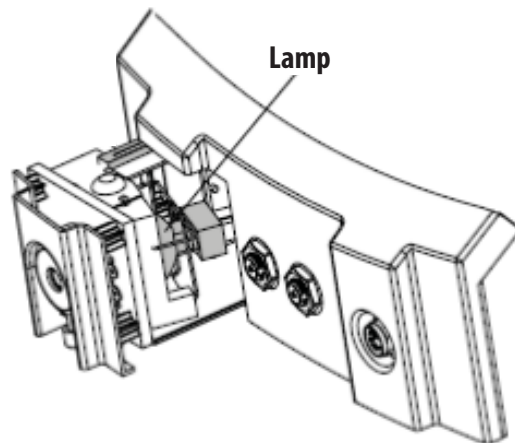

Figure 11: Lamp

TRIVEX SYSTEM FUSES

The control unit is protected by dual, 6.3 amp/250 volt time delay fuses mounted on the rear panel to the right of the three- pronged electrical connector. If the control unit fails to power-up when properly connected to a 100–240 volt ($\pm 10\%$) AC power source, check the fuses in the rear panel.

To replace the rear panel fuses:

 **WARNING:** To prevent electrical shock, unplug the unit from the electrical outlet before attempting to replace the fuses.

1. Disconnect the unit from the power source.
2. Locate the fuse tray just to the right of the power cord.
3. Use a slotted screwdriver to press the tab on the side of the fuse holder in, toward the center of the fuse tray.
4. Slide the fuse tray out.
5. Replace the fuses with 6.3 amp/250 volt time delay fuses.

 **WARNING:** To avoid fire hazard, use only fuses of the correct type, voltage rating, and current rating.

6. Insert the tray into the holder until the tab click into place.
7. Reapply power to the unit.

NOTE: Blown fuses usually indicate a short circuit or a failed component. Make sure components are properly interconnected. If the problem persists, contact LeMaitre Vascular Customer Service for troubleshooting assistance.

RETURNING THE TRIVEX SYSTEM CONTROL UNIT

In the event of a System Error code or some other failure of the TRIVEX System Control Unit, remove the unit from its stand and ship it back to LeMaitre Vascular in its original box.

1. Unplug and remove the power cord from the TRIVEX System Control Unit.
2. Remove the footswitch connectors, fiber optic cable and adaptor, resector handpiece cable, and all tube sets.
3. Using the 3/16" Allen wrench located at the base of the irrigation mast, remove the four mounting bolts and detach the irrigation mast.
4. Using the 3/16" Allen wrench, remove the four bolts securing the rear panel to the roller base. Remove the rear panel.
5. Locate the four drawer latches on the upper- interior of the roller base. For each of the four drawer latches: Lift the latch key and turn it one-half turn counterclockwise. Then lift and disengage the keeper.
6. Lift the TRIVEX Control Unit straight up from the roller base.
7. Repack the TRIVEX Control Unit in its original carton and ship back per instructions provided by LeMaitre Vascular.

TROUBLESHOOTING

SERVICE INDICATIONS

During system operation, the TRIVEX System runs a concurrent diagnostic routine in the background, checking inputs from the attached components. When the system detects a condition that requires attention, an orange or green indicator light is lit on the front panel. In many cases, the system will continue to operate normally, but occasionally allowable resector speed will be reduced. If the procedures below do not resolve the problem, the unit should be referred to qualified personnel for service.

Symptom	Possible Cause	Remedy
The TRIVEX System fails to come on when power switch is pressed.	The unit is not connected to power.	Plug into a power outlet of suitable rating. Ensure that both ends of the power cord are properly connected.
	Lamp assembly drawer is not fully closed.	Check lamp drawer to be sure that it is fully seated into its housing.
Lamp ON/OFF button indicator light is flashing green.	Lamp self-test.	The lamp is running a self-test. Wait 10-40 seconds for self-test to finish.
Lamp ON/OFF button indicator light is flashing orange.	Defective lamp.	Replace the lamp. See Service/ Maintenance for instructions on replacing the lamp.
The light output is low.	The light cable is not in the light source adaptor correctly.	Reseat the fiber optic cable. Check to see if the light source adaptor is in the correct position.
	Illuminator defective.	Replace the illuminator.
	Defective lamp.	Replace the lamp module.
	Wrong light source portal adaptor attached to fiber optic cable.	Use only the TRIVEX System Light Source adaptor (REF 7210375).

Resector Mode Select button indicator light is flashing green.	Moisture in resector handpiece or resector cable connectors.	Disconnect the cable from the control unit. Check the cable connector for moisture. If wet, rinse the connector with distilled water and dry completely.
	There is a problem with the resector handpiece.	If the flashing green persists, the resector handpiece is damaged; contact your LeMaitre Vascular representative.
No light from light guide.	Light guide adaptor latch did not catch.	Check light guide adaptor to ensure that it is fully seated into console.
Resector Mode Select button is flashing orange while handpiece Run button is held down.	The resector handpiece motor has stalled.	Remove and inspect the resector. Replace with a new resector if damaged.
		Run the handpiece without a resector. If the handpiece is still stalled, use alternate handpiece and contact your LeMaitre Vascular representative.
Resector Mode Select button indicator light is flashing orange after handpiece Run button is released.	High current warning for resector handpiece.	Contact your LeMaitre Vascular representative.
Resector Handpiece will not run and Resector Mode Select button indicator light is green.	Bad handpiece connector cable.	Check cable connections. Make certain the handpiece cable is fully inserted into the port on the front panel.
Resector Mode Select button indicator light is steady orange.	Resector Handpiece not connected.	Connect a resector handpiece to the TRIVEX System.
Resector Speed Display reads E-01 through E-15.	System Error.	Note the error code and contact your LeMaitre Vascular representative.
Tubing appears to be creeping through the pump.	Tubing forks not tight enough.	Tighten the tubing forks by one notch until tubing is secure, or contact your LeMaitre Vascular representative for specific adjustment instructions.
No fluid flow from peristaltic pump.	Pump head is not latched.	Check black pump closing lever to be sure it is fully closed.
	Pump rollers have seized.	Call Customer Service for return authorization.

TECHNICAL SPECIFICATIONS

TRIVEX SYSTEM CONTROL UNIT (7210386)

Dimensions:	22.6" wide x 24.2" deep x 64.0" high
Weight:	80 lbs
Power:	100–120/200–240 VAC 50/60 Hz, 350 VA
Equipment Classification:	Protection against electrical shock class 1 with BF type applied part. Protection against harmful ingress of water. (Ordinary equipment, none provided) Degree of safety of application in the presence of flammable anesthetics with mixture of air, oxygen, or nitrous oxide. (Not suitable)

FRONT PANEL

Lamp ON/OFF Button:	Turns the 50 Watt Metal Halide lamp On or Off and displays current lamp status.
Resector Speed Display:	4 character digital display—actual speed for installed resector.
Resector Mode Select Button:	Single momentary push button used to select the Resector Mode.
Resector Mode Display:	Two left-facing arrows and two right-facing arrows—display resector mode: Forward (>>), Reverse (<<), and Oscillate (<>).
Resector Speed Buttons:	Two momentary push buttons for increasing and decreasing speed settings.
Resector Window Lock Display:	Pressing and holding both the Resector Speed Buttons at the same time sets the Resector Window Lock.
Tumescence Pump Flow Buttons	Two momentary push buttons for increasing or decreasing Tumescence pump flow.
Saline Pump Flow Buttons:	Two momentary push buttons for increasing or decreasing Saline pump flow.
Pump ON/OFF Buttons:	Two momentary push buttons for starting or stopping the Saline pump or the Tumescence pump.
Connectors:	Light Source port, two Footswitch cable connectors, and a Resector Handpiece connector

REAR PANEL

Power ON/OFF: Rocker switch
AC Power: Detachable cord with a three-pin hospital-grade connector. Power input circuit automatically detects AC power standard.
Fuses: Two 6.3 amp/250 volt time delay fuses (Littel Fuse, Inc., P/N 021806.3HXP).

TRIVEX RESECTOR HANDPIECE (REF 7210387)

Handpiece with push-button motor and window lock controls.

Length: 7.1"
Weight: 8.5 oz.

Equipped with 10-foot (3-meter) autoclavable, replaceable resector handpiece cable.

TRIVEX SYSTEM FOOTSWITCH (REF 7209791)

Two supplied.

Dimensions: 4.00" wide x 5.50" deep x 1.75" high
Weight: 7.5 oz

ORDERING INFORMATION

TRIVEX SYSTEM COMPONENTS

REF	DESCRIPTION
2141	VERSITIP ACMI Adaptor
7205180	Gemini Universal Light Guide
7209791	TRIVEX System Footswitch
7210351	TRIVEX System Illuminator
7210375	VERSITIP , TRIVEX Adaptor
7210386	TRIVEX System Control Unit
7210387	TRIVEX System Resector Handpiece
7210414	TRIVEX System Cart
8005600	U.S. Power Cord
8013378	U.K. Power Cord
8013380	International Power Cord
1248-00	China Power Cord

TRIVEX SYSTEM DISPOSABLES/ACCESSORIES

REF	DESCRIPTION
7205683	Autoclavable Storage and Sterilization Tray
7209513	Illuminator Inflow Tubing
7209514	TRIVEX , 4.5 mm Blade and Tubing
7209515	TRIVEX, 5.5 mm Blade and Tubing
7210115	Replacement Lamp

GUIDANCE AND MANUFACTURER'S DECLARATION – ELECTROMAGNETIC EMISSIONS

Guidance and Manufacturer's Declaration – Electromagnetic Emissions		
The LeMaitre Vascular TRIVEX System is intended for use in the electromagnetic environment specified below. The customer or the user of the LeMaitre Vascular TRIVEX System should assure that it is used in such an environment.		
Emissions Test	Compliance	Electromagnetic Environment - Guidance
RF emissions CISPR 11	Group 1	The LeMaitre Vascular TRIVEX System uses RF energy only for its internal functions. Therefore, the RF emissions are very low and are not likely to cause any interference in nearby electronic equipment.
RF emissions CISPR 11	Class A	The LeMaitre Vascular TRIVEX System is suitable for use in all establishments other than domestic and those directly connected to the public low-voltage power supply network that supplies buildings used for domestic purposes
Harmonic emissions IEC 61000-3-2	Class A	
Voltage fluctuations/ flicker emissions IEC 61000-3-3	Complies	

GUIDANCE AND MANUFACTURER'S DECLARATION – ELECTROMAGNETIC IMMUNITY

Guidance and Manufacturer's Declaration – Electromagnetic Immunity			
The LeMaitre Vascular TRIVEX System is intended for use in the electromagnetic environment specified below. The customer or the user of the LeMaitre Vascular TRIVEX System should assure that it is used in such an environment.			
Immunity Test	IEC 60601 Test Level	Compliance Level	Electromagnetic Environment - Guidance
Electrostatic (ESD) Discharge IEC 61000-4-2	± 6kV contact ± 8kV air	± 6kV contact ± 8kV air	Floors should be wood, concrete or ceramic tile and the relative humidity should be at least 30%.
Electrical fast transient/burst IEC 61000-4-4	± 2kV for power supply lines ± 1kV for input/output lines	± 2kV for power supply lines ± 1kV for input/output lines	Mains power quality should be that of a typical commercial or hospital environment.
Surge IEC 61000-4-5	± 1kV differential mode ± 2kV common mode	± 1kV differential mode ± 2kV common mode	Mains power quality should be that of a typical commercial or hospital environment
Voltage dips, short interruptions and voltage variations on power supply input lines IEC 61000-4-11	<95% dip in UT for 1/2 cycle 60% dip in UT for 5 cycles 30% dip in UT for 25 cycles >95% dip in UT for 5 sec	<95% dip in UT for 1/2 cycle 60% dip in UT for 5 cycles 30% dip in UT for 25 cycles >95% dip in UT for 5 sec	Mains power quality should be that of a typical commercial or hospital environment. If the user of the LeMaitre Vascular TRIVEX System requires continued operation during power mains interruptions, it is recommended that the LeMaitre Vascular TRIVEX System be powered from an uninterruptible power supply or a battery.
Power frequency (50/60 Hz) magnetic field IEC 61000-4-8	3 A/m	3 A/m	The power frequency magnetic field should be at levels characteristic of a typical location in a typical commercial or hospital environment
<i>NOTE: UT is the a.c. mains voltage prior to application of the test level.</i>			
Conducted RF IEC 61000-4-6	3 Vrms 150 kHz to 80 MHz	3 Vrms	Portable and mobile RF communications equipment should be used no closer to any part of the LeMaitre Vascular TRIVEX System, including cables, than the recommended separation distance calculated from the equation applicable to the frequency of the transmitter. Recommended separation distance $d=1.2 \sqrt{p..}$ $d=1.2 \sqrt{p..}$ 80 MHz to 800 MHz $d=2.3 \sqrt{p..}$ 800 MHz to 2.5 GHz Where p is the maximum output power rating of the transmitter in watts (W) according to the transmitter manufacturer and d is the recommended separation distance in meters (m).
Radiated RF IEC 61000-4-3	3 V/m 80 MHz to 2.5 GHz	3 V/m	Field strength from fixed RF transmitters, as determined by an electromagnetic site survey, ^a should be less than the compliance level in each frequency range. ^b Interference may occur in the vicinity of equipment marked with the following symbol: 
NOTE 1: At 80 MHz and 800 MHz, the higher frequency range applies.			
NOTE 2: These guidelines may not apply in all situations. Electromagnetic propagation is affected by absorption and reflection from structures, objects, and people.			
^a Field strengths from fixed transmitters, such as base stations for radio, (cellular/cordless) telephones, land mobile radios, amateur radios, AM and FM radio broadcasts, and TV broadcasts cannot be predicted theoretically with accuracy. To assess the electromagnetic environment due to fixed RF transmitters, an electromagnetic site survey should be considered. If the measured field strength in the location in which the LeMaitre Vascular TRIVEX System is used exceeds the applicable RF compliance level above, the LeMaitre Vascular TRIVEX System should be observed to verify normal operation. If abnormal performance is observed, additional measures may be necessary, such as reorienting or relocating the LeMaitre Vascular TRIVEX System.			
^b Over the frequency range 150 kHz to 80 MHz, field strengths should be less than 3 V/m.			

GUIDANCE FOR SEPARATION DISTANCES

Recommended separation distances between portable and mobile RF communications equipment and the LeMaitre Vascular TRIVEX System			
The LeMaitre Vascular TRIVEX System is intended for use in an electromagnetic environment in which radiated RF disturbances are controlled. The customer or user of the LeMaitre Vascular TRIVEX System can help prevent electromagnetic interference by maintaining a minimum distance between portable and mobile RF communications equipment (transmitters) and the LeMaitre Vascular TRIVEX System as recommended below, according to the maximum output power of the communications equipment.			
Rated Maximum Output Power of Transmitter W	Separation distance according to frequency of transmitter M		
	150 kHz to 80 MHz $d=1.2 \sqrt{p}$	80 MHz to 800 MHz $d=1.2 \sqrt{p}$	800 MHz to 2.5 GHz $d=2.3 \sqrt{p}$
0.01	0.12	0.12	0.23
0.1	0.38	0.38	0.73
1	1.2	1.2	2.3
10	3.8	3.8	7.3
100	12	12	23

For transmitters rated at a maximum output power not listed above, the recommended separation distance d in meters (m) can be estimated using the equation applicable to the frequency of the transmitter, where p is the maximum output power rating of the transmitter in watts (W) according to the transmitter manufacturer.

NOTE 1: At 80 MHz and 800 MHz, the separation distance for the higher frequency range applies.

NOTE 2: These guidelines may not apply in all situations. Electromagnetic propagation is affected by absorption and reflection from structures, objects, and people.

HARDWARE (CONTROL UNIT AND MDU)- NEW:

If you purchased a new device, then the following warranty applies:

Limited Product Warranty; Limitation of Remedies

LeMaitre Vascular, Inc. warrants that reasonable care has been used in the manufacture of this device. Except as explicitly provided herein, LEMAITRE VASCULAR (AS USED IN THIS SECTION, SUCH TERM INCLUDES LEMAITRE VASCULAR, INC., ITS AFFILIATES, AND THEIR RESPECTIVE EMPLOYEES, OFFICERS, DIRECTORS, MANAGERS, AND AGENTS) MAKES NO EXPRESS OR IMPLIED WARRANTIES WITH RESPECT TO THIS DEVICE, WHETHER ARISING BY OPERATION OF LAW OR OTHERWISE (INCLUDING, WITHOUT LIMITATION, ANY IMPLIED WARRANTY OF MERCHANTABILITY OR FITNESS FOR A PARTICULAR PURPOSE) AND HEREBY DISCLAIMS THE SAME. LeMaitre Vascular makes no representation regarding the suitability for any particular treatment in which this device is used, which determination is the sole responsibility of the purchaser. This warranty applies to the original buyer of this device only. This limited warranty does not apply to the extent of any abuse or misuse of, or failure to properly store, this device by the purchaser or any third party. Damage inflicted on this device by the user that renders it unsuitable for refurbishment may result in additional charges, regardless of warranty status. The sole remedy for a breach of this limited warranty shall be repair or replacement of this device (at LeMaitre Vascular's sole option) following the purchaser's return of the device to LeMaitre Vascular. This warranty shall terminate on the date that is twelve months from the date of invoice for such device.

IN NO EVENT SHALL LEMAITRE VASCULAR BE LIABLE FOR ANY DIRECT, INDIRECT, CONSEQUENTIAL, SPECIAL, PUNITIVE, OR EXEMPLARY DAMAGES. IN NO EVENT WILL THE AGGREGATE LIABILITY OF LEMAITRE VASCULAR WITH RESPECT TO THIS DEVICE, HOWEVER ARISING, UNDER ANY THEORY OF LIABILITY, WHETHER IN CONTRACT, TORT, STRICT LIABILITY, OR OTHERWISE, EXCEED ONE THOUSAND DOLLARS (US\$1,000), REGARDLESS OF WHETHER LEMAITRE VASCULAR HAS BEEN ADVISED OF THE POSSIBILITY OF SUCH LOSS, AND NOTWITHSTANDING THE FAILURE OF THE ESSENTIAL PURPOSE OF ANY REMEDY. THESE LIMITATIONS APPLY TO ANY THIRD-PARTY CLAIMS.

A revision or issue date for these instructions is included on the back page of these Instructions for Use for the user's information. If twenty-four (24) months has elapsed between this date and product use, the user should contact LeMaitre Vascular to see if additional product information is available.

HARDWARE- REFURBISHED:

If you purchased a refurbished device, then the following warranty applies:

Limited Product Warranty; Limitation of Remedies

LeMaitre Vascular, Inc. warrants that reasonable care has been used in the manufacture of this device. Except as explicitly provided herein, LEMAITRE VASCULAR (AS USED IN THIS SECTION, SUCH TERM INCLUDES LEMAITRE VASCULAR, INC., ITS AFFILIATES, AND THEIR RESPECTIVE EMPLOYEES, OFFICERS, DIRECTORS, MANAGERS, AND AGENTS) MAKES NO EXPRESS OR IMPLIED WARRANTIES WITH RESPECT TO THIS DEVICE, WHETHER ARISING BY OPERATION OF LAW OR OTHERWISE (INCLUDING, WITHOUT LIMITATION, ANY IMPLIED WARRANTY OF MERCHANTABILITY OR FITNESS FOR A PARTICULAR PURPOSE) AND HEREBY DISCLAIMS THE SAME. LeMaitre Vascular makes no representation regarding the suitability for

any particular treatment in which this device is used, which determination is the sole responsibility of the purchaser. This warranty applies to the original buyer of this refurbished device only. This limited warranty does not apply to the extent of any abuse or misuse of, or failure to properly store, this device by the purchaser or any third party. Damage inflicted on this device by the user that renders it unsuitable for refurbishment may result in additional charges, regardless of warranty status. The sole remedy for a breach of this limited warranty shall be repair or replacement of this device (at LeMaitre Vascular's sole option) following the purchaser's return of the device to LeMaitre Vascular. This warranty shall terminate on the date that is three months from the date of invoice for such device.

IN NO EVENT SHALL LEMAITRE VASCULAR BE LIABLE FOR ANY DIRECT, INDIRECT, CONSEQUENTIAL, SPECIAL, PUNITIVE, OR EXEMPLARY DAMAGES. IN NO EVENT WILL THE AGGREGATE LIABILITY OF LEMAITRE VASCULAR WITH RESPECT TO THIS DEVICE, HOWEVER ARISING, UNDER ANY THEORY OF LIABILITY, WHETHER IN CONTRACT, TORT, STRICT LIABILITY, OR OTHERWISE, EXCEED ONE THOUSAND DOLLARS (US\$1,000), REGARDLESS OF WHETHER LEMAITRE VASCULAR HAS BEEN ADVISED OF THE POSSIBILITY OF SUCH LOSS, AND NOTWITHSTANDING THE FAILURE OF THE ESSENTIAL PURPOSE OF ANY REMEDY. THESE LIMITATIONS APPLY TO ANY THIRD-PARTY CLAIMS.

A revision or issue date for these instructions is included on the back page of these Instructions for Use for the user's information. If twenty-four (24) months has elapsed between this date and product use, the user should contact LeMaitre Vascular to see if additional product information is available.

SERVICE REPLACEMENT UNITS WARRANTY

The TRIVEX System replacement units are warranted to be free from defects in material and workmanship for 90 days from the date of original invoice unless otherwise provided by local law.

REPLACEMENT PROGRAM

LeMaitre Vascular offers a Replacement Program for TRIVEX System Control Units to minimize downtime in your operating room. With an active Replacement Agreement in place, a replacement TRIVEX System Control Unit will be shipped within 48-hours via next day delivery*. For a Return Goods Authorization (RGA) number or for additional information on this program, call Customer Service at 1-800-628-9470 in the U.S., or contact your LeMaitre Vascular representative.

*Next day delivery is not offered in all countries.

REPAIR SERVICE PROGRAM

For devices no longer under warranty, repairs can be made by LeMaitre Vascular. Non-warranty repairs will be made at the list price of replacement parts, plus labor. We will provide an estimate of repair cost and time required for the repair before any work is completed. Repair items should be carefully repackaged, marked with the Return Goods Authorization (RGA) number, and returned postpaid to the address provided by LeMaitre Vascular. LeMaitre Vascular Customer Service or your local representative can provide shipping information.



Distributed By:

LeMaitre Vascular, Inc.
Customer Service:
Tel: 781 221-2266
Fax: 781 221-2223

LeMaitre Vascular GK
1F Kubodera Twin Tower Bldg.
2-9-4 Kudan-minami, Chiyoda-ku
Tokyo 102-0074, Japan
Tel: +81-(0)3-5215-5681

LeMaitre Vascular ULC
5915 Airport Road, Suite 608
Mississauga, Ontario
Canada L4V 1T1
Tel: +1 905 673-2266

EC REP

LeMaitre Vascular GmbH
Otto-Volger-Str. 5a/b
65843 Sulzbach/Ts., Germany
Tel: +49-(0)6196-659230



LeMaitre Vascular, Inc.
63 Second Avenue
Burlington, MA 01803